

## PRESSED SASH SHUTTERS



The sash shutters until Ø 300 mm are made by two steel pressed parts (thickness 1,2 o 1,5 mm) welded together and galvanized. The diaphragm is made by pressed galvanized steel (thickness 1,2 o 1,5mm). Standard with edges. Maximum air speed : 35 m/s. AVAILABLE IN STAINLESS STEEL

-Possibility to mount pressed flanges only from Ø>220mm

**SAPØ 80 ÷ 300 mm:** pneumatic with cylinder

**SAPMØ 80 ÷ 300 mm:** elettropneumatic with electrovalve (voltage available 110Vac - 220Vac - 24Vac - 24Vdc)

**SAE Ø 80 ÷ 300 mm:** electric with actuator 220Vac or 24Vcc complete of protection "CE". Closing speed 18mm/s

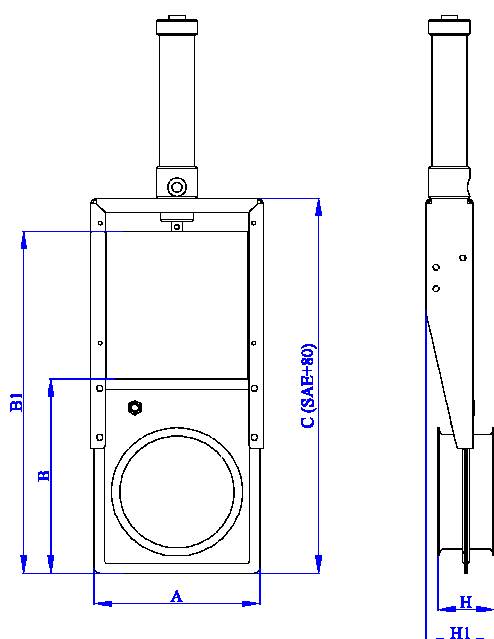

SAP - SAE								
Ø mm	A	B	B1	C	D	H	H1	Kg
80	120	150	240	280	420	40	60	1,1
100	145	190	300	330	490	50	60	1,3
120	165	210	340	370	550	50	65	1,5
125	165	210	350	370	550	50	65	1,5
140	180	220	375	405	605	50	65	1,7
150	190	237	405	415	615	50	65	1,8
160	205	245	415	445	660	50	65	1,9
180	220	280	490	530	750	50	65	2,3
200	240	310	545	545	795	50	65	2,5
220	270	330	560	595	880	65	80	3,8
225	285	330	560	595	880	75	80	3,9
240	290	340	590	630	930	55	80	4,7
250	305	362	620	650	950	65	80	5
260	315	370	640	675	980	75	90	5,8
280	335	390	675	705	1040	65	90	6,7
300	360	410	710	740	1095	80	90	7,5